

Features

- Quasar actuators are for awning windows, casement windows, hoppers, curtain wall vents and skylights.
- Multiple vents can be wired in parallel, and can be operated by building automation systems.
- Synchro Quasar-L is a version of the Synchro Quasar with longer chain options in a longer case.
- 30" and 40" strokes are only suitable for hopper windows or side-hinged windows that open inward.
- One 24"/600mm chain operator opens a 48" tall/264 lb. or an 82" tall/451 lb. window or vent.
- One 30"/750mm chain operator opens a 48" tall/134 lb. or an 82" tall/229 lb. window or vent.
- One 40"/1000mm chain operator opens a 48" tall/54 lb. or an 82" tall/92 lb. window or vent.
- Operator has stainless steel, double-link chain for rigidity and durability.
- Examples of 66 lbs operating force: 48" tall/528 lb. or a 82" tall/902 lb. vent (with 24" chain model)
- Low-profile, attractive aluminum case; available in Black, White or Grey paint.
- Minimum sash height is 24" (for 24" chain) or 30" (for 30" chain) and 40" (for 40" chain).
- Synchro Quasar-L F-Signal has opening and closing feedback signal, ask for data sheet.
- Two-year UCS manufacturer's warranty. Requires reading AFI Install Guide before purchase, and confirmation of project and installation specs by licensed electrical contractor.



Mounting brackets available separately

Synchro Quasar-L

Part #	Chain	Color	Stroke
41249T	24" Chain	Grey	Up to 600mm
41250U		Black	Up to 600mm
41251V		White	Up to 600mm
41252W	30" Chain	Grey	Up to 750mm
41253X		Black	Up to 750mm
41254Y		White	Up to 750mm
41255Z	40" Chain	Grey	Up to 1000mm
41256A		Black	Up to 1000mm
41257B		White	Up to 1000mm

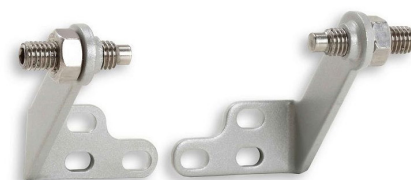

Mounting brackets ordered separately
Long Slim model, fits most profiles.

Mounting Brackets (Ordered separately)

Part #	Style	Color
41898F	Long Slim	Grey
41899G		Black
41900H		White
41901I	Short Slim	Grey
41902J		Black
41903K		White
40843F	Die-cast	Grey
40844G		Black
40845H		White



Specifications

Supply voltage	24VDC Low Voltage
Nom. Current draw	0.9A average
Limit stop	(Open): Built in limit switch (Closed) Integrated electronic power cut-off
Chain stroke (approx)	600mm (24"), 750mm (30") or 1000mm (40")
Push force (Max)	24" chain has 66 lbs (300N), 30" chain has 33 lbs, 40" chain has 22 lbs
Pull force (Max)	24" chain has 66 lbs (300N), 30" chain has 66 lbs, 40" chain has 66 lbs
Chain speed	15mm/sec
Dimensions	Height: 37mm (1 ⁷ / ₁₆ " Depth: 69mm (2 ⁴ / ₁₆ " Length (24" stroke model): 876mm (34 ¹ / ₂ " Length (30" stroke model): 951mm (37 ⁷ / ₁₆ " Length (40" stroke model): 1076mm (42 ³ / ₈ "
Power cable	UL cable 1.5 meter included, white color
Run/Rest cycle	For every 60 sec running (on), must then rest (off) for 120 sec
Ambient Oper Temp	-10 °C to +60 °C (14 °F to 140 °F)
Listing	UL Listed
Protection class	IP20
Colors	Powder-coated: Grey (RAL 9006), White (RAL 9010), or Black (RAL 9005)
Opening mechanism	Stainless steel chain, chain is centered in case

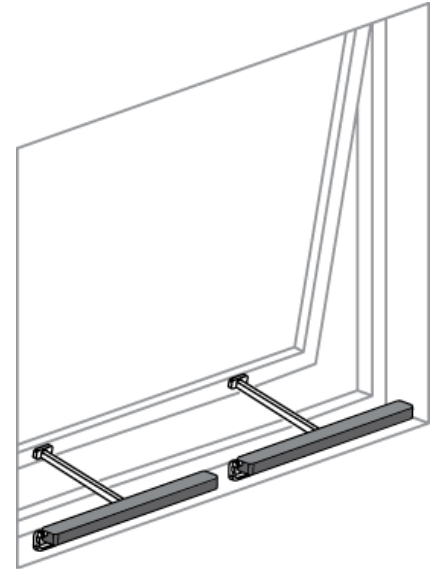

Synchro Quasar is for wide vents providing multiple sash connection points and synchronized operation.