

## Features

- Quasar actuators are for awning windows, casement windows, hoppers, curtain wall vents and skylights.
- Synchro Quasar is for wide vents that require 2 to 4 motors, providing multiple sash connection points and synchronized operation. Available in low voltage 24VDC only.
- Multiple vents can be wired in parallel, and can be operated by building automation systems.
- Available as 15" (380mm) or 20" (500mm) chain operator; self-adjusting for proper closure at installation.
- Operator has stainless steel, double-link chain for rigidity and durability.
- Examples of 66 lbs operating force: 48" tall/844 lb. or a 264 lb. skylight (with 15" chain).
- Low-profile, attractive aluminum case; available in Black, White or Grey paint.
- Minimum sash height is 12" for 15" chain (16" for 20" chain).
- Synchro Quasar F-Signal has opening and closing feedback signal, ask for data sheet.
- Two-year UCS manufacturer's warranty. Requires reading AFI Install Guide before purchase, and confirmation of project and installation specs by licensed electrical contractor.



Mounting brackets available separately

## Synchro Quasar

Part #	Chain	Color	Stroke (and force)
<b>41172N*</b>	15" Chain	Grey	Up to 380mm (200N)
<b>41173R*</b>		Black	Up to 380mm (200N)
<b>41174T*</b>		White	Up to 380mm (200N)
<b>41175V</b>	20" Chain	Grey	Up to 500mm (200N)
<b>41176X</b>		Black	Up to 500mm (200N)
<b>41177Z</b>		White	Up to 500mm (200N)

\* 10 unit minimum order quantity on 15" chain models.

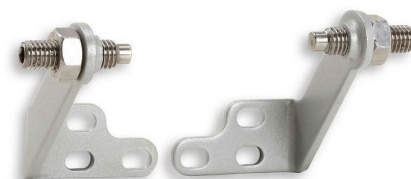

Mounting brackets ordered separately  
Long Slim model, fits most profiles.

## Mounting Brackets (Ordered separately)

Part #	Style	Color
<b>41898F</b>	Long Slim	Grey
<b>41899G</b>		Black
<b>41900H</b>		White
<b>41901I</b>	Short Slim	Grey
<b>41902J</b>		Black
<b>41903K</b>		White
<b>40843F</b>	Die-cast	Grey
<b>40844G</b>		Black
<b>40845H</b>		White

## Specifications

<b>Supply voltage</b>	24VDC Low Voltage
<b>Nom. Current draw</b>	0.9A average
<b>Limit stop</b>	(Open): Built in limit switch (Closed) Integrated electronic power cut-off
<b>Chain stroke (approx)</b>	380mm (12") or 500mm (20")
<b>Push force (Max)</b>	66 lbs (200N)
<b>Pull force (Max)</b>	66 lbs (200N)
<b>Chain speed</b>	15mm/sec
<b>Dimensions</b>	676 x 47.5 x 32mm (26 <sup>5</sup> / <sub>8</sub> " x 1 <sup>7</sup> / <sub>8</sub> " x 1 <sup>1</sup> / <sub>4</sub> " )
<b>Power cable</b>	UL cable 1.5 meter included, white color
<b>Run/Rest cycle</b>	For every 60 sec running (on), must then rest (off) for 120 sec
<b>Ambient Oper Temp</b>	-10 °C to +60 °C (14 °F to 140 °F)
<b>Listing</b>	UL Listed
<b>Protection class</b>	IP20
<b>Colors</b>	Powder-coated: Grey (RAL 9006), White (RAL 9010), or Black (RAL 9005)
<b>Opening mechanism</b>	Stainless steel chain, chain is centered in case

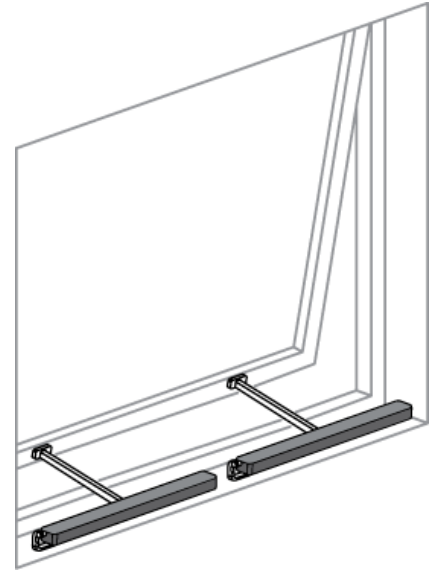

Synchro Quasar is for wide vents providing multiple sash connection points and synchronized operation.

